

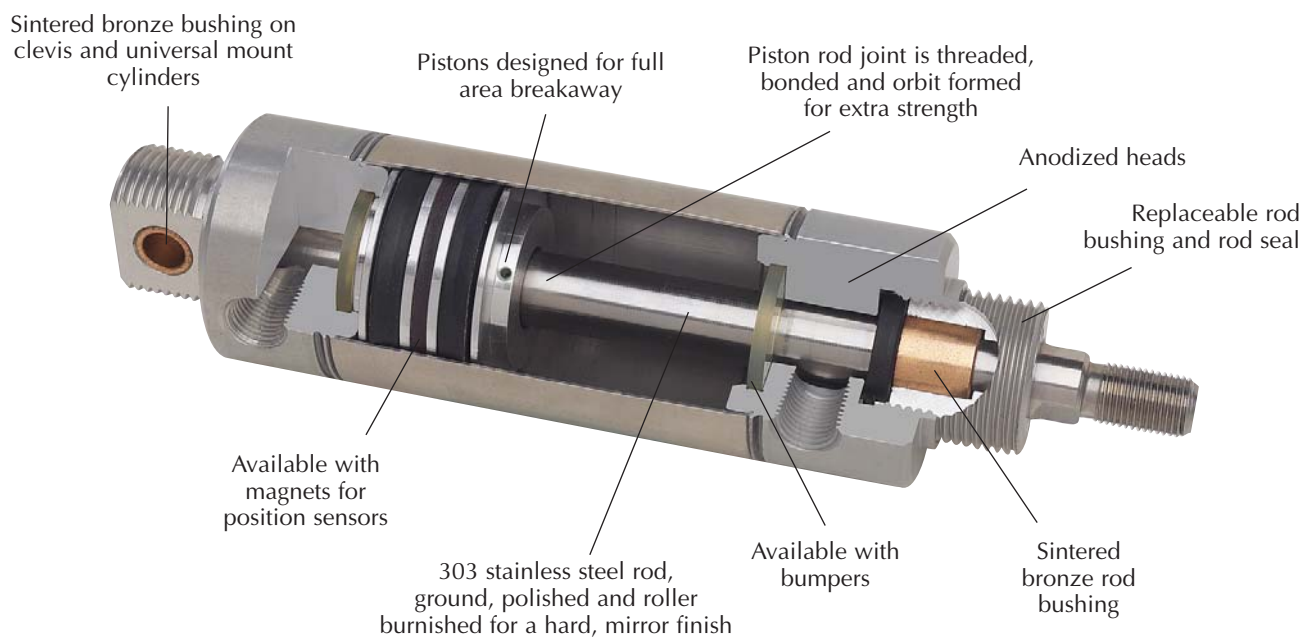

# STAINLESS STEEL CYLINDER CONSTRUCTION

In the early 1950's, Clippard introduced miniature pneumatic cylinders and valves to industry. No other manufacturer can boast of the same experience or knowledge of miniature components.

Air cylinders have always been an integral part of the Clippard Minimatic® line. Over the years Clippard has responded to requests from cylinder users to provide additional sizes of air cylinders and auxiliary support products. While competitively priced, these products maintain the Clippard standard for quality and reliability that has been the industry standard for many years.



## Features

- Polished I.D. 304 stainless steel tubes for low breakaway
- Precision rolled construction for a solid, leakproof cylinder at a reasonable price
- Machined aluminum heads are clear anodized for extra protection against corrosion
- Cylinder heads are machined from one side for better concentricity
- Sintered bronze rod bushing
- Sintered bronze clevis bushing on all clevis and universal mount cylinders
- Rods are threaded, bonded and orbit formed to pistons
- Replaceable rod seal on 28 through 48 series
- Ground, polished and roller burnished 303 stainless rods provide a smoother rod finish that protects rod seals, giving longer life
- Full piston area breakaway to assure full power from the beginning of each stroke
- Buna-N "U"-cup piston seals for full power, low friction and trouble-free performance
- Buna-N "U"-cup rod seals for leakproof operation
- Temperature range: 32 to 230°F
- Maximum pressure: 250 psig